

Adroit 622

4x4 Underground Personnel Carrying Vehicle



Adroit 622 provides perfect mobility for the workers in underground mines and has a capacity of 21+1 personnel. It has powershift drive system which offers front wheel control, four wheel steering and crab steering.

GENERAL SPECIFICATIONS

- > Led control panel showing fault, warning and driving info
- > Front and rear parking sensor
- > Front and rear projectors
- > Rear view camera
- > Reversing audible and visual warning system
- > Eyebolts and towing hooks to use in loading and transporting the machine
- > 12 VDC output inside the cabin for vehicle radio
- > Fire extinguisher
- > 21+1 personnel carrying capacity

DIMENSIONS AND WEIGHT

- > Length 7000 mm
- > Width 2200 mm
- > Height 2500 mm
- > Weight 6000 kg

OPERATOR CABIN

- > Laminated and tempered glasses
- > Heated glasses and side-view mirrors
- > Washable cabin upholstery
- > 3 points contacted, non-slippery stairs
- > Emergency stop button inside the cabin
- > Operator seat
 - Suspended
 - Retractable seat belt
 - Sensor that activates the park brakes when the operator stand up

ENGINE

- > Cummins ISF 2.8 110 kW@3200 rpm Diesel engine Euro Stage 3A
- > Engine / radiator fluid level warning

EXHAUST SYSTEM

- > Catalytic converter with diesel particle filter

TRANSMISSION

- > Allison automatic transmission
- > 5 speed forward and 1 speed reverse
- > 4 wheel drive

AXLE SYSTEM

- > Planetary type Dana 211
- > Solid axle, coil spring suspension

TIRES

- > 12.5 - 20 size heavy duty tires, suitable for underground work

PERFORMANCE

- > Max. speed 35 km
- > Fully loaded max. speed in 24% incline : 15 km/h
- > Max. climb gradient 40%

BRAKE SYSTEM

- > Service brake: Hydraulically powered two circuit oil immersed multidisc brake in both axles
- > Parking brake: S.A.H.R fail safe brake
- > Brake systems test set-up in cabin

STEERING

- > Four wheel steering, crab steering, front wheel steering

FUEL SYSTEM

- > Tank capacity 80 L
- > Fuel hose securely fixed and isolated from the hot surfaces

HYDRAULIC SYSTEM

- > Tank capacity 30 L
- > Hydraulic filtration, fluid temperature and tank fluid level sensing and warning system

ELECTRICAL SYSTEM

- > Electrical components : IP65 and above protection grade
- > Battery 135 Ah
- > Led lighting lamps illuminating the movement direction
- > Flashing beacon lamps in amber colour
- > Fire - resistant wiring

OPTIONAL COMPONENTS

- > EU Stage 5 diesel engine
- > Diesel engine fire suppression system

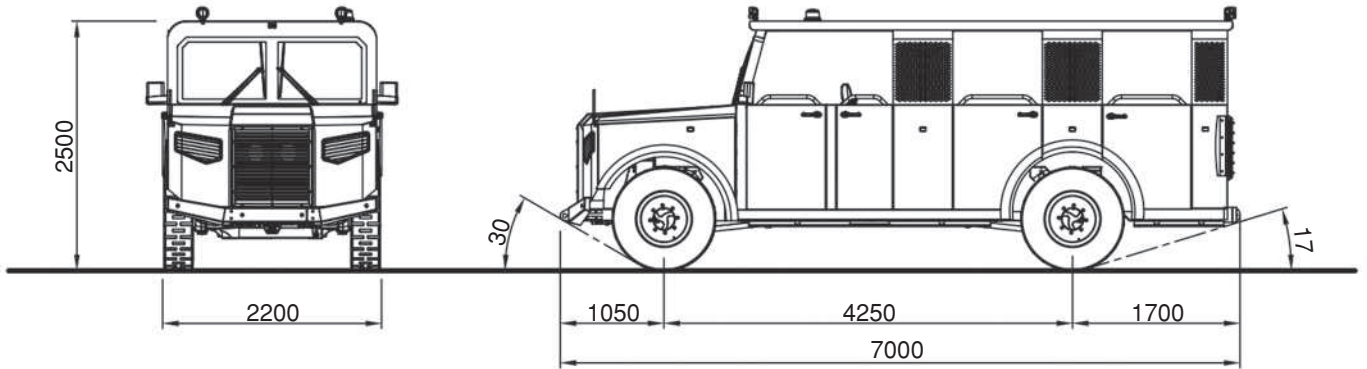

Climbing Capacity

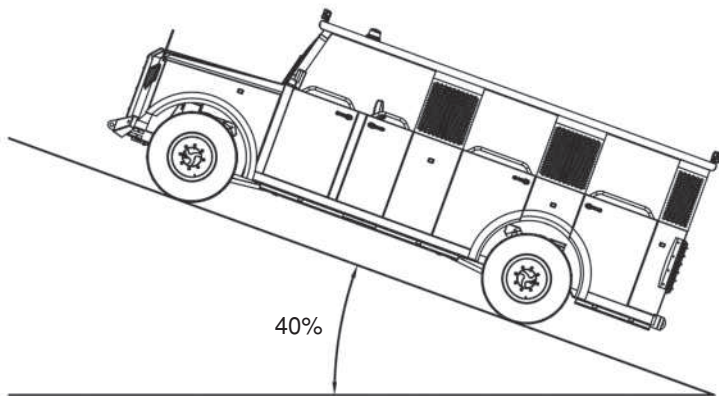

Max. Speed - Max. Power of Climbing

Adroit 622 with 5-speed automatic transmission system offers long distance drives on flat terrains and have capacity of 40% gradient climbing.

Max. speed 35 km and fully loaded max. speed in 24% incline 15 km/h.

Turning Radius

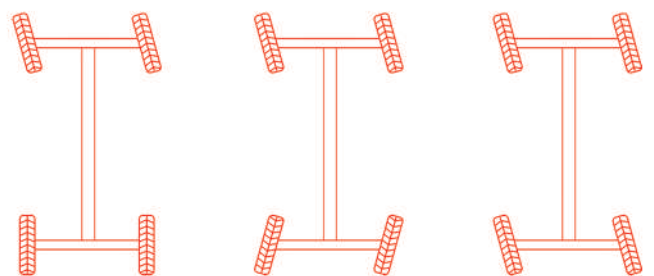
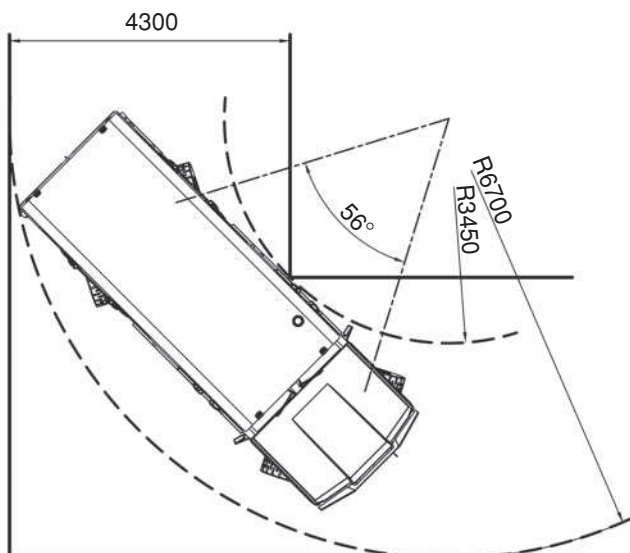

Front Wheel Control

Four Wheel Steering

Crab Steering